

Min table height (Pump cables not shown)

**FRONT VIEW**  
Scale - 1:10

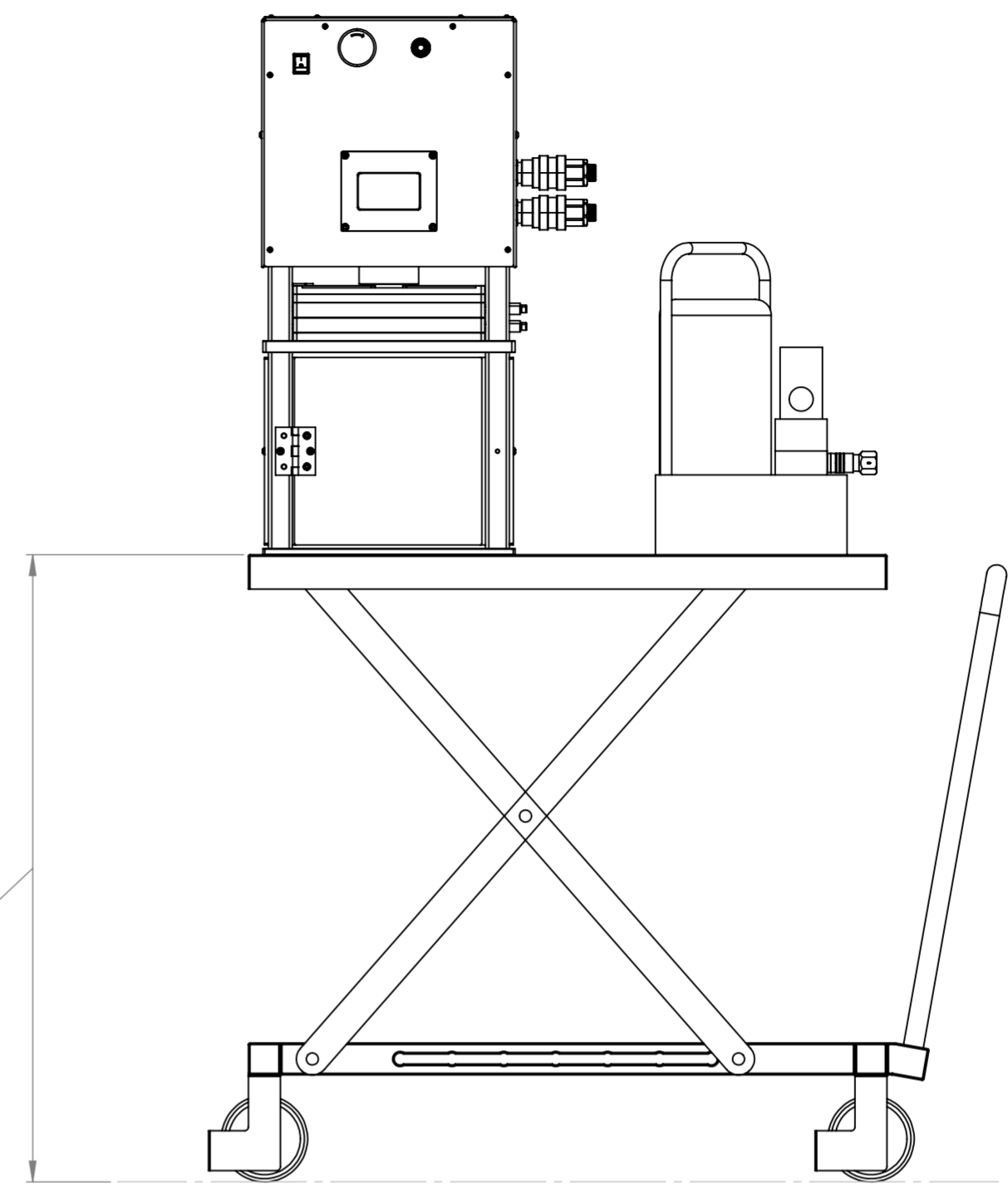

Max table height (Pump cables not shown)

**TOP VIEW**  
Scale - 1:10

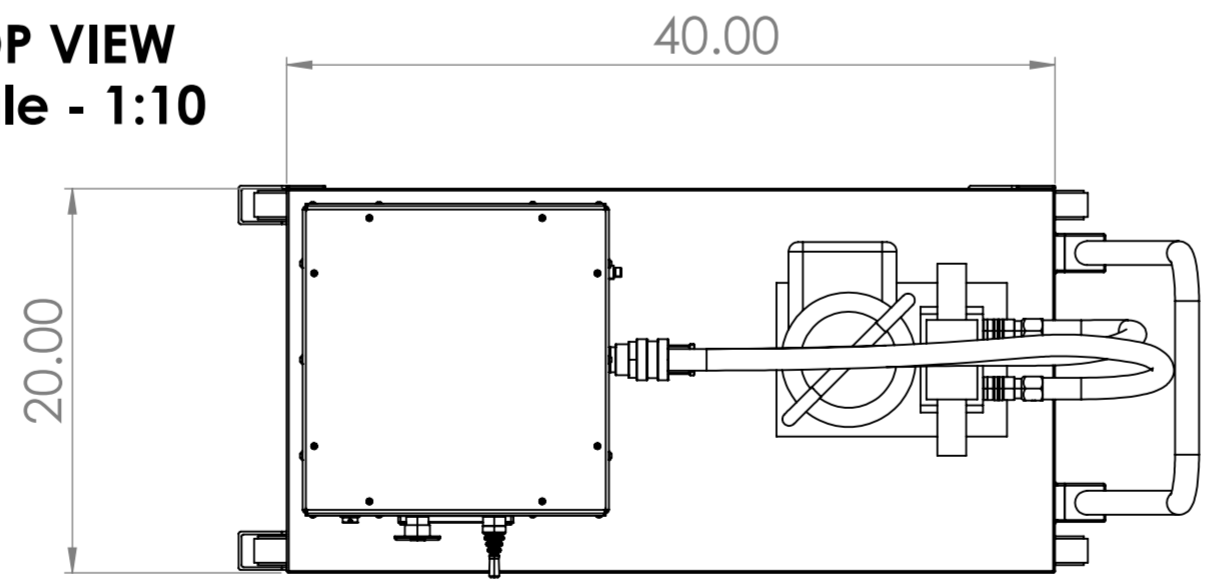

- NOTES:**
1. All dimensions are in Inches with +/- 0.1 in tolerance
  2. See the product only assembly drawing for press details.

UNLESS OTHERWISE SPECIFIED: DIMENSIONS ARE IN MILLIMETERS			FINISH:		DEBURR AND BREAK SHARP EDGES		DO NOT SCALE DRAWING		REVISION	
SURFACE FINISH:										
TOLERANCES:										
LINEAR:										
ANGULAR:										
DRAWN			NAME	SIGNATURE	DATE			TITLE:		
CHK'D										
APPV'D										
MFG										
Q.A										
			MATERIAL:		DWG NO.					
							drw_full_KWAD_press_V12_(with c			
			WEIGHT:		SCALE:1:10		SHEET 2 OF 2			